

INSTRUCTION MANUAL

ESPRIT 150 ED Super APO



Sky-Watcher®
Be amazed.

SL131119

Table of contents

Introduction.....	2
Getting started.....	3
Parts description	3
Unpacking the telescope.....	3
Preparing the telescope for an observation.....	4
Cooling the telescope	4
Aligning the finderscope	5
Using the telescope for visual observation.....	6
Inserting the eyepiece.....	6
Focusing	6
Prime focus imaging with the optional field flattener	7
Installing the field flattener and a DSLR (Digital Single-Lens Reflex) camera.....	7
Installing a 48mm filter inside the extender tube	8
Installing the field flattener and a CCD (Charge-Coupled Device) camera.....	8
Focusing	9
Framing the picture	9
Prime focus imaging with the optional 0.77x reducer / flattener.....	10
Installing the reducer flattener and a DSLR camera.....	10
Installing the reducer flattener and a CCD (Charge-Coupled Device) camera	11
Useful tips for all observations	13
Removing the finder scope.....	13
Using the indexed scale.....	13
Rotating the focuser.....	13
Specifications	14
Telescope specifications.....	14
Threads specifications	15
Different releases: Case and Accessory box.....	16

Introduction

The spirit of perfection, by Sky-Watcher

Designed with the discerning astronomer in mind, Sky-Watcher top-of-the-line Esprit refractors deliver the kind of imaging performance one would expect from telescopes costing much more. With their three-element air spaced objective lens design, false color is extremely well corrected, yielding exceptional contrast and sharpness.

The 3" CNC machined 1:11 rotatable dual speed linear power focuser provides a smooth, rock-solid focusing with zero image shifts. The Esprit ED 150mm refractor comes with a 9 x 50 right angle finder scope, 2-inch Star diagonal, D-style dovetail, retractable dew cap and padded case.

Quick overview:



- 150 mm apochromatic, 3-element refractor
- 1050 mm (f/7)
- Metallic high-transmission lens coatings
- 3" CNC machined 1:11 dual-speed focuser
- No visual color fringing even on bright objects
- Knife-edge Baffled Optical System
- 2" Diagonal with dielectric coatings
- 9x50 erect-image 90° finder scope
- Tube rings with dovetail D (Losmandy style) bar
- Aluminum foam lined case
- Optional thread-on full frame field flattener
- Optional thread-on full frame 0.77x reducer / field flattener



- NEVER USE YOUR TELESCOPE TO LOOK DIRECTLY AT THE SUN. PERMANENT EYE DAMAGE WILL RESULT.
- NEVER USE AN EYEPIECE-TYPE SOLAR FILTER.
- NEVER USE YOUR TELESCOPE TO PROJECT SUNLIGHT ONTO ANOTHER SURFACE; THE INTERNAL HEAT BUILD-UP WILL DAMAGE THE TELESCOPE OPTICAL ELEMENTS.
- USE A PROPER SOLAR FILTER FIRMLY MOUNTED ON THE FRONT OF THE TELESCOPE FOR VIEWING THE SUN.
- WHEN OBSERVING THE SUN, PLACE A DUST CAP OVER YOUR FINDERSCOPE OR REMOVE IT TO PROTECT YOU FROM ACCIDENTAL EXPOSURE.
- NEVER LET A TELESCOPE POINTING THE SUN UNATTENDED.

Getting started

Parts description

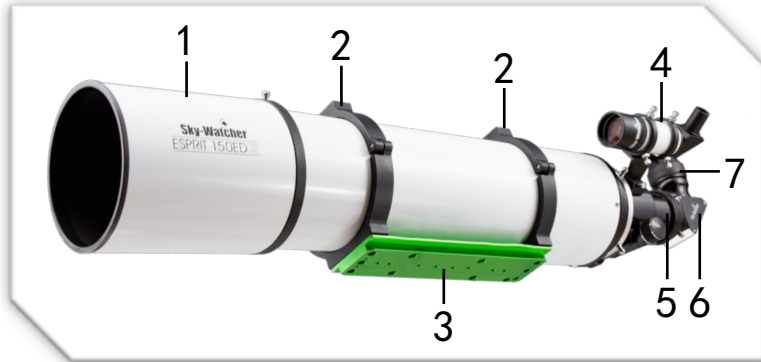

- 1. Retractable dew cap
- 2. Tube rings
- 3. D (Losmandy) dovetail bar
- 4. 9x50 erect-image 90° finder scope
- 5. 3" 1:11 dual-speed focuser
- 6. 2" dielectric diagonal
- 7. 2" eyepiece f= 28mm

Unpacking the telescope



Your telescope is inside the sturdy aluminum padded case, designed to securely carry the telescope and the tube rings. The case has two castors on one side to facilitate transport.

The case contains and protects the telescope and its accessories. Once open you will find:



- 1. The telescope with dew cap retracted.
- 2. The 9x50 erect-image finder scope with tube rings and mount.
- 3. The 2" (50.8mm) diagonal.
- 4. The 2-element thread-on field flattener (used for photography only), guarantees excellent field flatness across the entire 44 mm imaging plane, allowing picturing the sky with large sensors.
- 5. Field flattener extender tube for DSLR camera, used to place the camera exactly on the corrected focal plane.
- 6. 2" eyepiece, f= 28mm.
- 7. Thread-on field flattener adaptor, used to install the field flattener on the focuser's drawtube.

 **Some parts may be optional, depending on the dealer's country.**
Please check with him if any doubt.

Preparing the telescope for an observation



A. Upon delivery, and when not used, the telescope and its accessories are inside the aluminum padded case. Unpack the telescope and assemble it to your mount using the included D (Losmandy style) dovetail bar. Please refer to your mount manual to properly install the telescope.



B. To extend the dew cap unscrew the two screws on the aluminum ring (1), then gently pull the dew cap forward (2). When in position, tighten the two screws to ensure the dew cap stays in position (3).



C. The 9x50 erect-image finder scope is a small fixed magnification scope mounted on the optical tube. When it is correctly aligned with the telescope, objects can be quickly located and brought into the field of telescope (see also "*Aligning the finder scope*" chapter, on next page)

To install the finder scope on the telescope insert the positive dovetail of the finder scope support inside the negative dovetail mounted on the focuser, as shown in picture.

Cooling the telescope

Telescopes require time to cool down to outside air temperature. This may take longer if there is a big difference between the temperature of the telescope and the outside air. This minimizes heat wave distortion inside telescope tube (tube currents). Your telescope would require at least 30 minutes cooling off to outside conditions. Tip: use this time for planning your session and mount accessories.

Aligning the finder scope

The 9x50 erect-image finder scope is a small fixed magnification scope mounted on the optical tube. When it is correctly aligned with the telescope, objects can be quickly located and brought to the center of the field.

The alignment should be done at first use and over time if the alignment is no more accurate.



Alignment is best done outdoors in day light when it's easier to locate objects



If it is necessary to refocus your finder scope, sight on an object that is at least 500 meters (or yards) away. Loosen the locking ring by unscrewing it back towards the bracket. The front lens holder can now be turned in and out to focus. When focus is reached, lock it in position with the locking ring.



Choose a distant object that is at least 500 meters (or yards) away and point the main telescope at the object. Adjust the telescope so that the object is in the center of the view in your eyepiece.



If you are using the star diagonal the image will be left/right inverted, like images in a mirror.



Having an erected image, the view you have in the finder scope has the same orientation as the landscape.

Check the finder scope to see if the object, centered in the main telescope view, is centered on the crosshairs. If not unscrew the three blocking rings on the rear ring, then adjust the three small screws to center the finder scope.

Do not over tighten the screws when aligning the finder scope. When the finder scope is correctly oriented, screw the three blocking rings in position.

Using the telescope for visual observation

Inserting the eyepiece

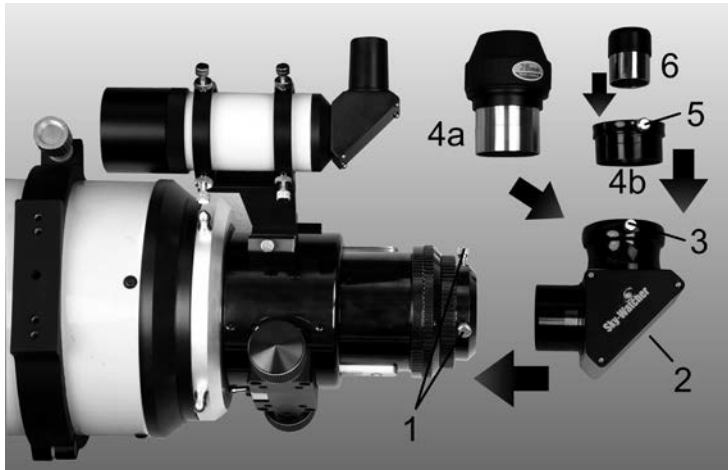

- Loosen the two thumbscrews (1) on the end of the focuser tube.
- Insert the 2" diagonal (2) into the focus tube and re-tighten the thumbscrews (1) to hold the diagonal in place.
- Loosen the diagonal's screw (3).
- For 2" eyepieces (4a), insert it into the diagonal and secure it by re-tightening the thumbscrew (3).
- For 1.25" eyepieces first insert the 2" to 1.25" adapter (4b) into the diagonal and secure by re-tightening the screw (3). Loosen the adapter's screw (5) and insert the 1.25" eyepiece (6) inside the adapter ring, then secure it by re-tightening the screw (5).

Focusing



- Make sure the locking lever below the focuser (1) is unlocked (position as shown in picture).
- Slowly turn the focus knobs (2) one way or the other, until the image in the eyepiece is nearly sharp.
- To finely focus the image turn the 1:11 knob one way or the other until the image is perfectly sharp (3).
- Lock the screw below the focuser (1) if a heavy load is attached (pull the lever at 90°).

The image usually has to be finely refocused over time, due to small variations caused by temperature changes. This often happens when the telescope has not yet reached outside temperature.

Refocusing is almost always necessary when you change an eyepiece.



When looking through a diagonal, the image is inverted left to right, as an image in a mirror. This is normal and has no incidence for astronomical observations.

If you plan to do terrestrial observation often, like bird watching, optional image-erecting devices such as the Amici prism or the erected 90° diagonal may be the right tool.

Your reseller will be glad to advise you about the best optional part that can be used with your telescope.

Prime focus imaging with the optional field flattener



Before installing the field flattener onto the drawtube of the focuser, the 2" ring adaptor (2) needs to be unscrewed and removed.

In order to easily unscrew the ring, hold with one hand the ring (1) at the end of the drawtube and then unscrew the 2" ring adaptor (2) with the other hand.



The Sky-Watcher ESPRIT 150 full frame field flattener has been specifically designed for your telescope. It guarantees excellent field flatness and ensures full illumination with extremely minimized color fringing across the entire 44 mm imaging plane.

No "universal" field flattener available on the market will deliver the premium results achieved with the Sky-Watcher ESPRIT 150 Field flattener.

The Sky-Watcher ESPRIT 150 Field flattener is **not compatible with other telescopes**, even refractors with the same aperture and same focal length.

Installing the field flattener and a DSLR (Digital Single-Lens Reflex) camera

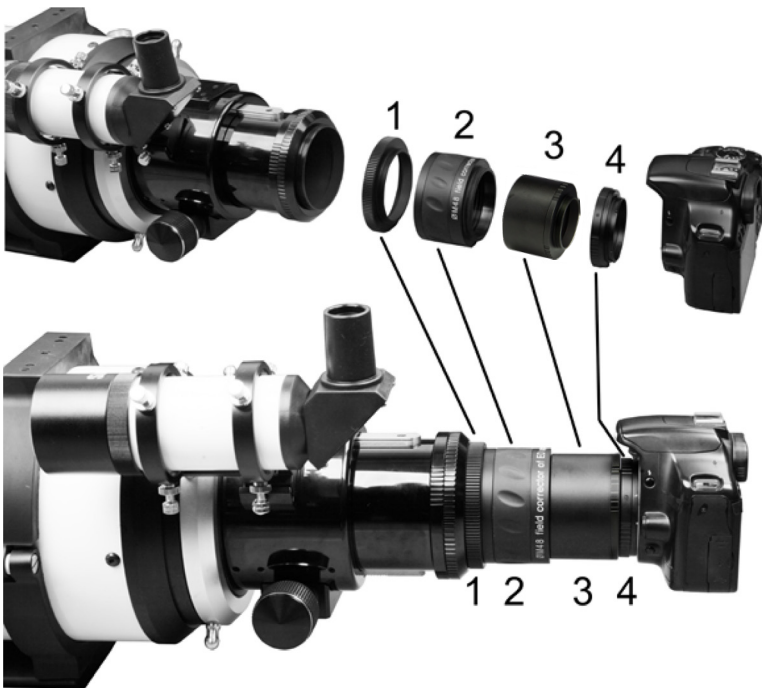

1. Screw the drawtube adaptor (1) at the end of the focus tube.
2. Screw the field flattener (2) onto the drawtube adaptor (1).
3. Screw the extender tube (3) onto the field flattener (2).
4. Screw the enlarged 48mm T-Ring (4) onto the extender tube (3).



The enlarged 48mm T-Ring **may not be included with your telescope** and should match your DSLR camera's manufacturer and model. Please check with your reseller to get the correct 48mm Enlarged T-Ring for your DSLR camera.

5. Install your DSLR camera on the 48mm enlarged T-Ring (4).



In order to get the premium results the field flattener for ESPRIT 150 can deliver the distance between the last lenses to the sensor should be exactly 100mm. This distance is called the field flattener "back focus".

The rings are designed to provide 98mm of back focus with any DSLR camera. Modifications to this layout, i.e. by adding a radial guider, will lead to blurry stars images in the field edges.

Installing a 48mm filter inside the extender tube



A 48mm (2") filter can be mounted inside the DSLR extender tube if needed. By example using a light pollution reducer filter may allow pictures of the night sky even in suburban areas.

1. Unscrew the closing ring at the rear part of the extender tube.
2. This closing ring has a 48x0.75 mm thread inside, able to receive any 48mm (2") filter.
3. Insert the filter. Do not overtighten the filter. Put the closing ring back in place.



Installing the field flattener and a CCD (Charge-Coupled Device) camera

Installing an astronomical CCD camera and its accessories (filter wheel, radial guider...) behind the field flattener is not as straightforward as installing a DSLR camera. All DSLR cameras have the exact same distance from the border of the T-Ring adapter to the sensor, thus share the same extension rings to ensure the 98mm back focus distance.

CCD cameras differ from one model to another, even in the same brand name, by the threads used and the body-to-sensor distance. Accessories also have different possible threads and depths, thus the combination of a CCD camera and its accessories can have any total length and any coupling thread.

A custom coupling ring is needed in order to assemble the CCD camera and its accessories (called the "optical train") to the telescope's field flattener. The custom ring should be machined* to have:

- 1) A female M62x1 thread, to screw and secure the ring to the field flattener exit.
- 2) A thread compatible with the first component of the optical train.
- 3) A length to ensure that the distance **from the last lenses of the field flattener to the CCD sensor** is exactly 100mm.

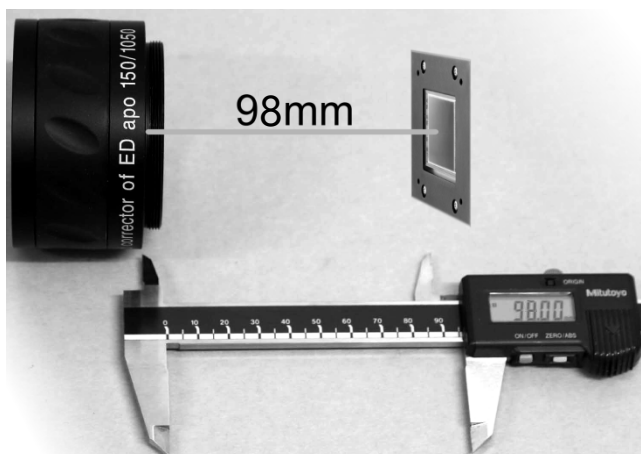

As it can be difficult to evaluate the position of the field flattener lenses inside the frame, the distance can be more conveniently measured from the lenses mount edge, as shown in the picture on the left.

From there to the sensor, the correct distance should be exactly 98mm.

Most CCD cameras have also the distance from their body thread to CCD sensor noted in the manual, thus evaluating the length of the custom ring you need can be precisely evaluated.

* Refer to your local dealer about custom ring supply.

Installing the field flattener and a CCD camera - continued



1. Screw the drawtube adaptor (1) at the end of the focus tube.
2. Screw the field flattener (2) onto the drawtube adaptor (1).
3. Screw the custom ring (3) onto the field flattener (2).



The custom ring needs to be sturdy enough to secure the optical train to the field flattener.

4. Screw your optical train to the custom ring (3).

Focusing



- Make sure the locking lever below the focuser (1) is unlocked (position as shown in picture).
- Slowly turn the focus knobs (2) one way or the other, until the image in the eyepiece is nearly sharp.
- To finely focus the image turn the 1:11 knob one way or the other until the image is perfectly sharp (3).
- Lock the screw below the focuser (1) if a heavy load is attached (pull the lever at 90°).

The image usually has to be finely refocused over time, due to small variations caused by temperature changes. This often happens when the telescope has not yet reached outside temperature.

Framing the picture

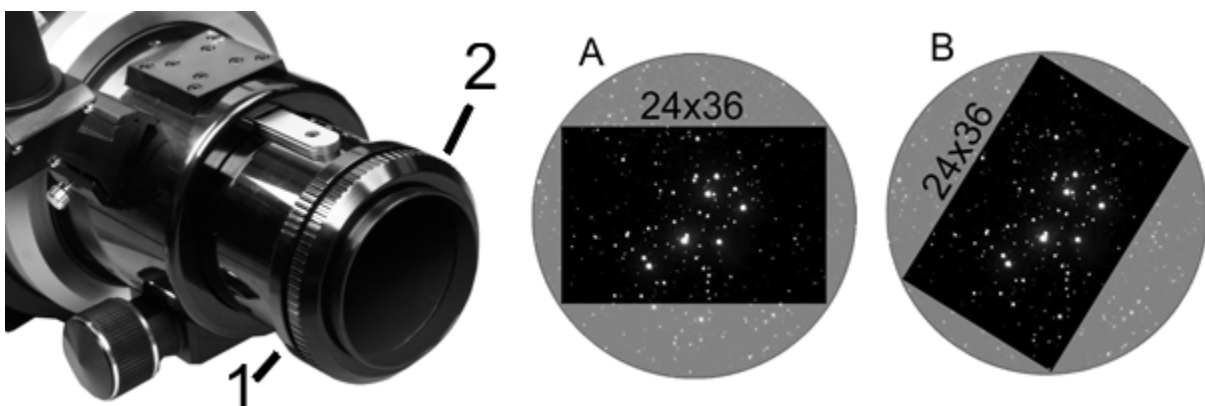

When the object you want to picture is in the middle of the circular 44mm field, most often its orientation on the rectangular camera sensor is not what you expected (figure A). You can easily reframe the picture on the camera sensor by unscrewing the blocking ring (1) at the end of the focuser drawtube, then turning the adapter ring (2) with all the optical train until the framing suits your needs (figure B). When done screw the ring (1) to lock position, and you are ready to picture the sky.

Prime focus imaging with the optional 0.77x reducer / flattener



Before installing the reducer flattener onto the drawtube of the focuser, the 2" ring adaptor (2) needs to be unscrewed and removed.

In order to easily unscrew the ring, hold with one hand the ring (1) at the end of the drawtube and then unscrew the 2" ring adaptor (2) with the other hand.



The Sky-Watcher ESPRIT 150 full frame 0.77x reducer / field flattener has been specifically designed for your telescope. It guarantees excellent field flatness and ensures full illumination with extremely minimized color fringing across the entire 34 mm imaging plane.

No "universal" reducer flattener available on the market will deliver the premium results achieved with the Sky-Watcher ESPRIT 150 Reducer flattener.

The Sky - Watcher ESPRIT 150 Reducer flattener **is not compatible with other telescopes**, even refractors with the same aperture and same focal length.

Installing the reducer flattener and a DSLR camera



1. Screw the reducer flattener onto the focuser drawtube.
2. Screw the extender tube onto the reducer flattener.
3. Screw the enlarged 48mm T-Ring onto the extender tube.
4. Install your DSLR camera on the 48mm enlarged T-Ring.

The enlarged 48mm T-Ring **may not be included with your telescope** and should match your DSLR camera's manufacturer and model. Please check with your reseller to get the correct 48mm Enlarged T-Ring for your DSLR camera.





In order to get the premium results the reducer flattener for ESPRIT 150 can deliver the distance between the last lenses to the sensor should be exactly 90mm. This distance is called the reducer flattener "back focus".

The rings are designed to provide 90mm of back focus with any DSLR camera. Modifications to this layout, i.e. by adding a radial guider, will lead to blurry stars images in the field edges.

Installing a 48mm filter inside the extender tube



A 48mm (2") filter can be mounted inside the DSLR extender tube if needed. By example using a light pollution reducer filter may allow pictures of the night sky even in suburban areas.

1. Unscrew the closing ring at the rear part of the extender tube.
2. This closing ring has a 48x0.75 mm thread inside, able to receive any 48mm (2") filter.
3. Insert the filter. Do not overtighten the filter. Put the closing ring back in place.

Installing the reducer flattener and a CCD (Charge-Coupled Device) camera

Installing an astronomical CCD camera and its accessories (filter wheel, radial guider...) behind the reducer flattener is not as straightforward as installing a DSLR camera. All DSLR cameras have the exact same distance from the border of the T-Ring adapter to the sensor, thus share the same extension rings to ensure the 55mm back focus distance.

CCD cameras differ from one model to another, even in the same brand name, by the threads used and the body-to-sensor distance. Accessories also have different possible threads and depths, thus the combination of a CCD camera and its accessories can have any total length and any coupling thread.

A custom coupling ring is needed in order to assemble the CCD camera and its accessories (called the "optical train") to the telescope's field flattener. The custom ring should be machined* to have:

- 1) A female M78x1 thread, to screw and secure the ring to the reducer flattener exit.
- 2) A thread compatible with the first component of the optical train.
- 3) A length to ensure that the distance **from the last lenses of the reducer flattener to the CCD sensor** is exactly 90mm .

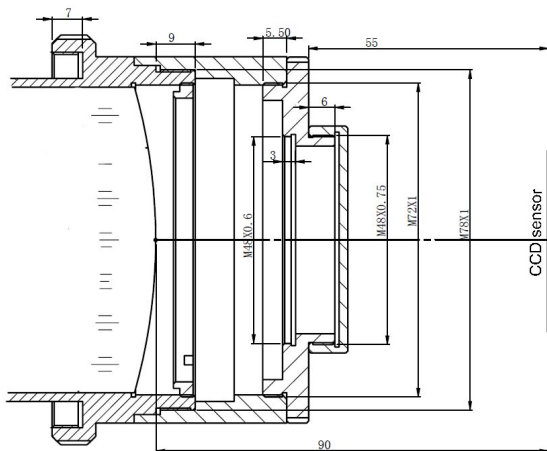

As it can be difficult to evaluate the position of the reducer flattener lenses inside the frame, the distance can be more conveniently measured from the lenses mount edge.

The 90mm distance is measured from the edge marking the start of the M78x1 male thread on the reducer flattener, to the CCD sensor (see picture on the left).

Most CCD cameras have also the distance from their body thread to CCD sensor noted in the manual, thus evaluating the length of the custom ring you need can be precisely evaluated.

*

Refer to your local dealer about custom ring supply.

Installing the reducer flattener and a CCD camera - continued



1. Screw the reducer flattener on the end of the focus tube.
2. Screw the custom ring onto the field flattener.
3. Screw your optical train to the custom ring.



The custom ring needs to be sturdy enough to secure the optical train to the field flattener.

4. Screw your optical train to the custom ring.

Useful tips for all observations



Removing the finder scope

During an observation, when the desired target is acquired, it is possible to remove the finder scope from its support. When needed the finder scope can be inserted again.

This can be useful when the observer's head is in a position where the finder scope becomes an obstacle to observation.



Using the indexed scale

The indexed scale on the focuser drawtube gives an accurate indication on the focus position for various accessories.

Once the position for one accessory is known it is very easy to approximate the focus position.

Due to the precision needed to reach perfect focus a fine tuning is advised.



Rotating the focuser

The whole focuser body can be rotated. It is useful when the focuser knobs aren't in a convenient position.

1. Remove all accessories from the focuser.
2. Fully retract the drawtube inside the focuser body.
3. Unscrew the "boat wheel" like large aluminum ring.
4. Rotate the focuser body.
5. Tight back the "boat wheel" like large aluminum ring.

Specifications

Telescope specifications

<i>Optical Design</i>	Refractor (air-spaced triplet APO)
<i>Aperture (mm)</i>	150 mm (5.9 in)
<i>Focal Length</i>	1050 mm (41 in)
<i>Focal Ratio</i>	7
<i>Highest Useful Magnification</i>	354 x
<i>Lowest Useful Magnification</i>	21 x
<i>Limiting Stellar Magnitude</i>	13.4
<i>Resolution (Rayleigh)</i>	0.93 arc seconds
<i>Resolution (Dawes)</i>	0.77 arc seconds
<i>Light Gathering Power</i>	459 x (Compared to Human Eye)
<i>Optical Coatings</i>	Fully multi-coated
<i>Optical Tube Length</i>	92 cm (36 in) (Retracted Dew Cap)
<i>Optical Tube Weight</i>	15 kg (32 lbs)
<i>Telescope Visual Backfocus</i>	>170mm (6.7 in)
<i>Focuser type</i>	Rack and pinion, double speed, diameter 74mm (3 in)

Telescope accessories specifications

<i>Mounting</i>	Tube Rings With 3" (D Style) dovetail plate
<i>Finderscope</i>	9x50, erect-image, right-angle
<i>Diagonal</i>	2" dielectric coatings

Field Flattener:

<i>Optical Design</i>	2 lenses
<i>Resulting focal length</i>	unchanged 1050mm (F/D=7)
<i>Field of view</i>	Full frame (44mm diameter unvignetted)
<i>Backfocus</i>	** 98mm (3.86 in)
<i>Telescope side connection</i>	M65x1 (inside)
<i>Camera side connection</i>	M62x1 (outside)
<i>Filter compatible</i>	2" filter compatible in DSLR extension adapter
<i>Telescope side adapter</i>	M74x1 (in) to M65x1 (out)
<i>Camera side adapter</i>	DSLR extension adapter M62x1 (in) to M48x0.75 (out)

0.77x Reducer / Field Flattener:

<i>Optical Design</i>	3 lenses
<i>Resulting focal length</i>	810mm (F/D=5.4)
<i>Field of view</i>	Full frame (36mm diameter unvignetted)
<i>Backfocus</i>	** 90mm (3.54 in)
<i>Telescope side connection</i>	M86x1 (inside)
<i>Camera side connection</i>	M78x1 (outside)
<i>Filter compatible</i>	2" filter compatible in DSLR extension adapter
<i>Camera side adapter</i>	DSLR extension adapter M78x1 (in) to M48x0.75 (out)

Threads specifications

Field flattener and DSLR adapter threads specifications



Rings/ Threads	Focuser Tube	Drawtube Adatpor	Field Flattener	DSLRI Ext. Tube	Enlarged T-Ring
In Ø	n/a	M74x1 F.	M65x1 F.	M62x1 F.	M48x0.75 F.
In screw depth	n/a	7 mm	7.5 mm	8.5 mm	variable
Out Ø	M74 x1 M	M65x1 M.	M62x1 M.	M48x0.75 M	Camera
Out screw depth	6 mm	6 mm	6 mm	6 mm	n/a

0.77x reducer / field flattener and DSLR adapter threads specifications



Rings/ Threads	Focuser Tube	Field Flattener	DSLRI Ext. Tube	Enlarged T-Ring
In Ø	n/a	M86x1 F.	M78x1 F.	M48x1 F.
In screw depth	n/a	7 mm	9 mm	variable
Out Ø	M86 x1 M	M78x1 M.	M48x0.75 M	Camera
Out screw depth	7 mm	9 mm	6 mm	n/a

* The visual back focus of the telescope is the distance from the end of the focuser tube (with 2" adapter installed) to the focal plane. This means, all accessories needing 170mm back focus or less can be installed.

** The back focus of the field flattener is the distance from the back of the field flattener (flat surface at the exit) to the focal plane. To obtain flat wide field images, the sensor should be positioned at exactly (+1mm) this distance. See also detailed explanations on bottom of page 8.

Different releases*: Case and Accessory box

Some of the first ESPRIT 150 series are delivered with a different case and accessory box.



Your telescope is inside the sturdy aluminum padded case, designed to securely carry the telescope and the tube rings.



The accessory box contains the following parts:



1. The 2" (50.8mm) diagonal with dielectric coating.
2. The 9x50 erect-image finder scope with tube rings and mount.
3. The 2-element thread-on field flattener, used for photography only, guarantees excellent field flatness across the entire 44 mm imaging plane, allowing picturing the sky with large sensors.
4. Thread-on field flattener adaptor, used to install the field flattener on the focuser's drawtube.
5. Field flattener extender tube for DSLR camera, used to place the camera exactly on the corrected focal plane.
6. 2" eyepiece $f=28\text{mm}$

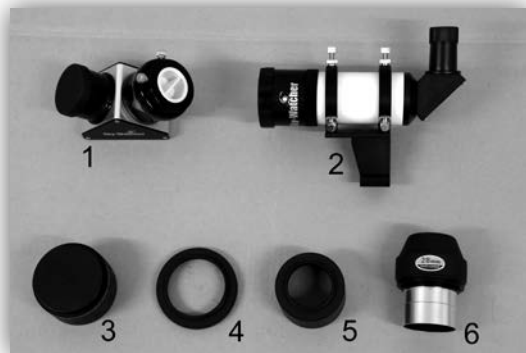

Some parts may be optional, depending on the dealer's country.

Please check with him if any doubt.

* Sky-Watcher offers this product with the best available quality in accordance with the legislation of the local market. This can lead to small differences over time and depending on the area of sale in the world. These differences do not influence the overall quality which is of the high standard guaranteed by Sky-Watcher worldwide.



We want to ensure that your experience with a Sky-Watcher product is the best it can be. To make that happen we have a comprehensive technical and customer support available, alongside with the list of distributors and dealers worldwide, on our worldwide internet site:

<http://www.skywatcher.com>

Sky-Watcher offers this product with the best available quality in accordance with the legislation of the local market, and reserves the right to modify or discontinue, without prior notice to you, any model or style telescope.