

UVEX spectroscope User Manual



François Cochard
(francois.cochard@shelyak.com)

March 3rd, 2021

Ref. DC0037 - rev A-01

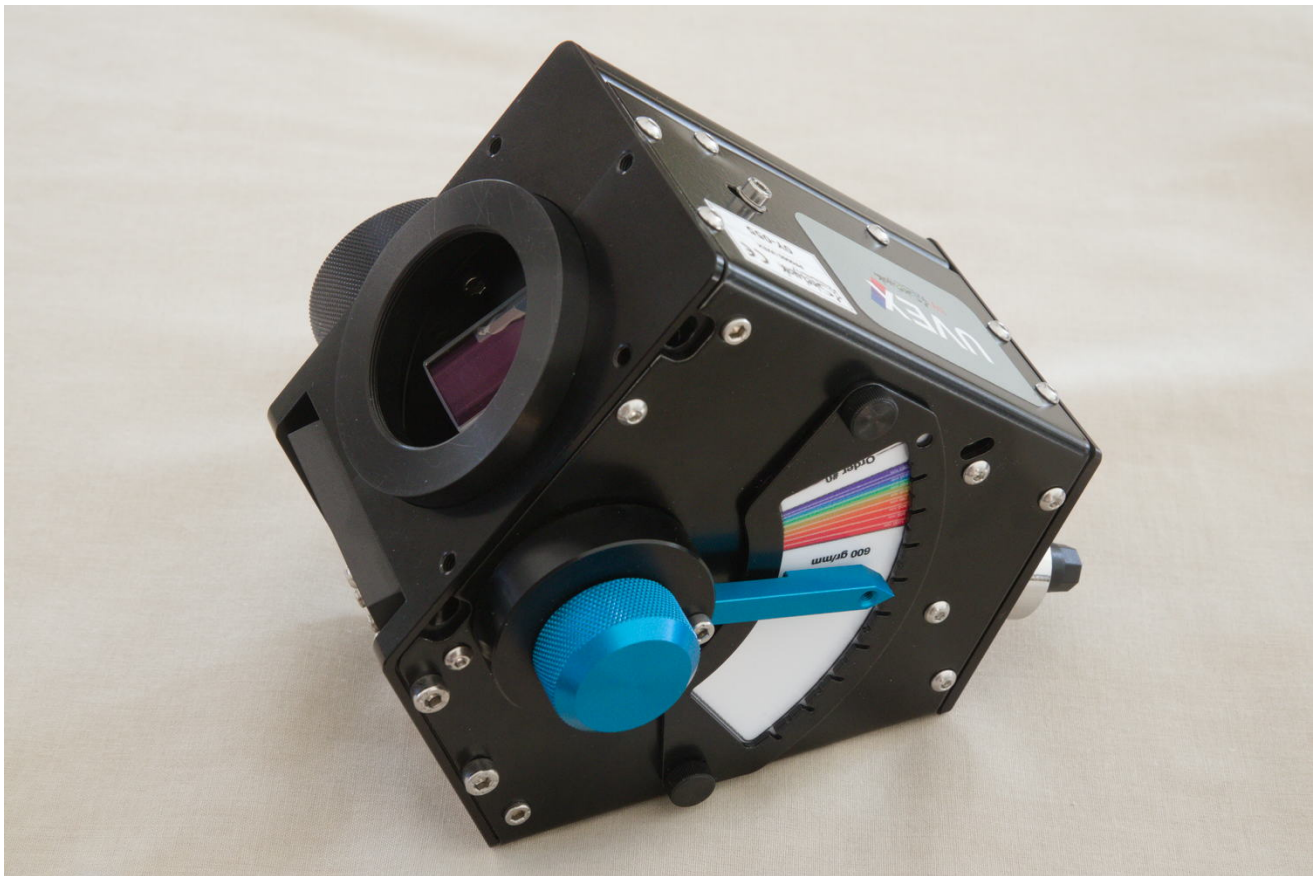

Table des matières

Introduction	3
1 Presentation of the UVEX	5
1.1 Out of the Box	5
1.2 Overview of the UVEX	5
1.3 Optical Architecture	5
1.4 Steps for Starting With The UVEX	6
2 Installing & Tuning the Instrument	7
2.1 Attaching the Camera	7
2.2 Attaching the Guiding Module	8
2.3 Selecting the Grating Angle	9
2.4 Focusing the Cylindrical Lens	10
2.5 Changing the Grating	10
2.6 Installation on the telescope	12
3 Using the UVEX	14
3.1 Focusing the Spectrum	14
3.2 Selection of the Central Wavelength	14
3.3 Tuning the Exposure Time	15
Appendix A : technical specifications	16
Appendix B : changing the slit	18
Appendix C : installing the order filter	20
Appendix D : screws functions	21
Appendix E : tuning the M1 mirror tilt	22

Welcome to the world of Spectroscopy with your UVEX!

It was a great pleasure to design this instrument, and now we hope that you'll take a lot of pleasure to use it for observing stars and other sky objects.

The UVEX is a compact spectroscope, specially designed for small telescope (say up to 0.3m) – but you can also use it opportunistically use it on bigger instruments. It opens to you new windows on the Universe, from UV to IR domain.

This is a multi-purpose instrument : you can install it on different telescopes, use different gratings, different slits. It is the perfect instrument for exploring the sky.

Because the UVEX is made only with mirrors, you should prefer to use it with a pure mirror telescope (ie Newton, Ritchey-Chretien, or Cassegrain optics). This way you'll have a fully achromatic setup.

This documentation only describes technical elements of the UVEX. If you need more general informations about spectroscopy (how to obtain a high quality star spectrum), please refer to the book "Succesfully Starting in Astronomical Spectroscopy"¹.

François COCHARD
March 2021

1. "Succesfully Starting in Astronomical Spectroscopy – a practical guide", François Cochard, EDP Sciences, 2018, ISBN 978-2-7598-2026-9

1

Presentation of the UVEX

1.1 Out of the Box

Your UVEX is shipped within a robust case. Here are the elements that you'll find in the case (see picture 1.1)

- UVEX spectroscope
- Rigid case
- The different verniers, matching each potential grating (gratings are optional)¹
- A flyer that indicates where you can find this documentation
- Tool set :
 - crosshead screwdriver (Phillips PH00)
 - hexagonal screwdriver (2 mm)
 - hexagonal wrenchs (1.5, 2.5 and 3 mm)
- spare screws



FIGURE 1.1 – All the elements in the box

1.2 Overview of the UVEX

In the pictures below (fig. 1.2 to fig. 1.4), you'll see the different elements of the UVEX :

- Grating index

- Grating locker knob
- Focus button
- Vernier, to indicate the grating angle
- Slit & telescope beam input
- Main camera output
- Camera adapter
- Grating locker knob
- Cylindrical lens position screw
- Cylindrical lens locking screw

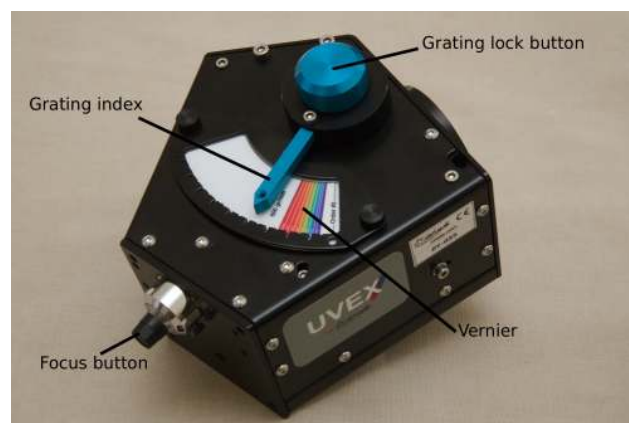

FIGURE 1.2 – Overview of the UVEX (1)

1.3 Optical Architecture

The UVEX is based on a crossed Czerny-Turner architecture. It is made of two spherical mirrors (M1 = collimator mirror and M2 = objective mirror), and the diffraction grating. See optical schematic 1.5.

The input slit makes a thin and controlled light source at the spectroscopy input.

1. This is a paper printed version of the verniers (you can find the PDF file on the Shelyak website). Each grating (including the 600l/mm grating shipped with the UVEX) is shipped with its own vernier, made in a waterproof plastic sheet.

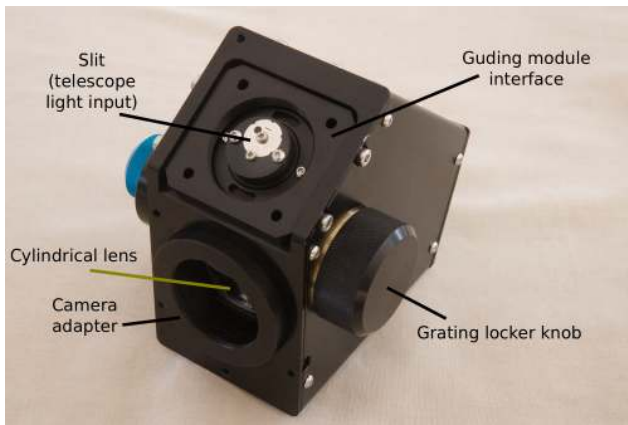

FIGURE 1.3 – Overview of the UVEX (2)

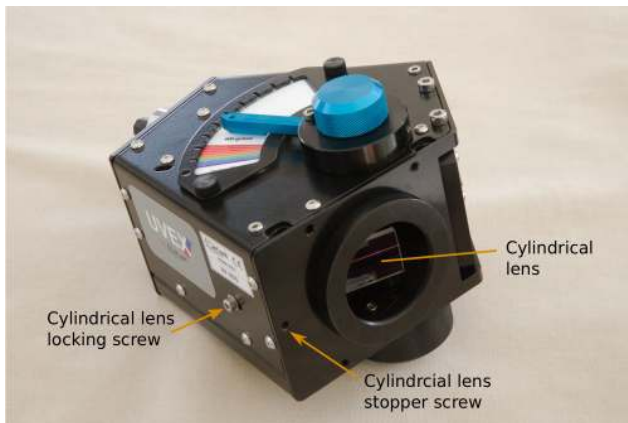

FIGURE 1.4 – Overview of the UVEX (3)

This is the usage of two mirrors for main optics that makes the UVEX to go far in blue (UV) and red (IR) ends; a mirror is purely achromatic.

The grating angle can be changed easily, to select the central wavelength you want to observe. And you can also change the grating to change the actual resolution of the instruments (standard grating is 600g/mm, other grating are optional - 150, 300, 1200 and 1800g/mm).

This schematic has a natural astigmatism that gives a wide spectrum on the camera sensor plane. To avoid this affect, and concentrate more light on each pixel, we've added a cylindrical lens at the end of the light path (close to the main camera).

1.4 Steps for Starting With The UVEX

When you receive your UVEX and start using it, we recommend to follow these steps (described in detail in next chapter) :

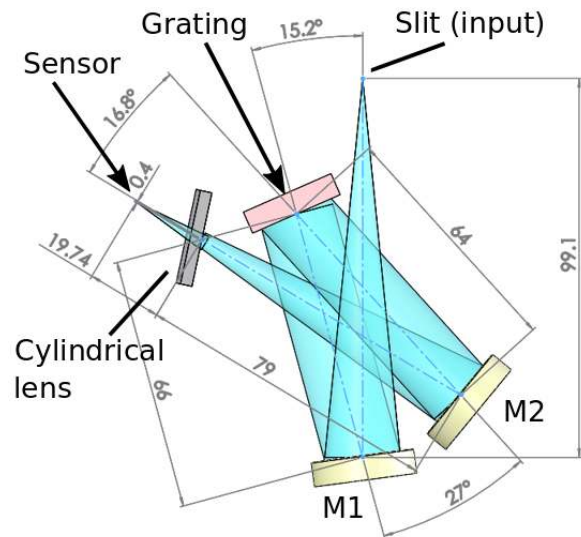

FIGURE 1.5 – Optical schematic

→ Install your camera on the UVEX, and take first spectra on a table. Use any light source you've around (sky, ambient light).

→ Play with the different tunings (rotation of the camera, focusing the spectrum, tuning the cylindrical lens).

→ Then install the Guiding and calibration modules.

→ Put an optics in front of the UVEX, and run a full observation (including reference images and data reduction).

→ Once all is under control, you can install the UVEX on your telescope and start observing for real.

Always keep in mind that the telescope and the spectroscope are two different devices that must be put under control before attaching them together – it will be much simpler.

We recommend to use the Demetra-UVEX software² (the version of Demetra dedicated to the UVEX) for all your observations and tests. This software includes all features to make your work easy during tuning, acquisition and data reduction. Of course, you can also use any software that you want, since the UVEX will create standard images.

2. Demetra-UVEX is free, and can be downloaded on Shelyak website <https://www.shelyak.com>

2

Installing & Tuning the Instrument

In this chapter, we give details on the installation of each element around the UVEX.

2.1 Attaching the Camera

The acquisition camera is attached to the UVEX thanks to a special adapter (included in the UVEX).¹ The adapter ensures that the sensor (CCD or CMOS) is exactly in the image focal plane of the UVEX. It also allows the tuning of the camera rotation in such a way that the spectrum is precisely horizontal in the image – this is much better for the data processing, and then the quality of the final result.



Note about the camera backfocus. Because of the optical architecture of the UVEX, the camera must have a short backfocus (max 13mm). Make sure that your camera fits this need. If not, you'll not be able to focus the spectrum properly.

Follow these steps :

→ The camera adapter is attached to the UVEX with three M4 headless screws around (see fig. 2.1 to 2.3). First loosen these headless screws and remove the adapter (use a Hex wrench or screwdriver of 2.5mm); see fig. 2.4.

→ Attach the adapter to the camera. Tighten it firmly (not too much however!).

→ Install the camera on the UVEX, making sure that the orientation of the camera is correct (see fig. 2.5).

→ Tighten the three screws around the adapter.

Make sure that the camera is strongly attached to the UVEX. There must be NO movement of



FIGURE 2.1 – First screw of the camera adapter



FIGURE 2.2 – Second screw of the camera adapter

the camera when the telescope will move around the sky.

1. Different adapters are available for Atik, QHY and ZWO cameras. The standard adapter is the ZWO one.



FIGURE 2.3 – Third screw of the camera adapter



FIGURE 2.4 – Third screw of the camera adapter



To make sure that the camera orientation is correct, you can proceed as follows :

- Rotate the camera roughly; the sensor longest dimension must be in the optical plane of the instrument.
- check with taking images that the spectrum is properly oriented : the blue part must be to the left, and the red part to the right. A single way to check this is to (very) slightly move the grating angle from blue to red; the spectrum must move in the screen toward the left.
- Precisely adjust the camera orientation to make the the spectrum is exactly horizontal in the image.



FIGURE 2.5 – Orientation of the camera

2.2 Attaching the Guiding Module

The UVEX is shipped with a guiding module adapter². This adapter attaches the UVEX to the Guiding module, and then to the telescope. It also gives an easy access to the slit, if you need to change it or clean it.

The adapter is attached to the UVEX with 4 (M4) screws on the sides (fig. 2.6).

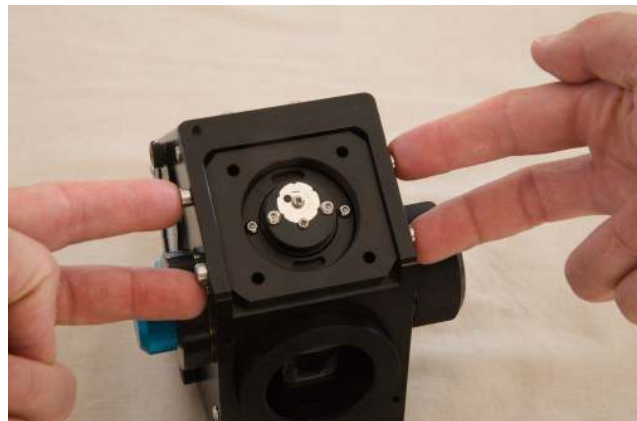

FIGURE 2.6 – Screws to remove the guiding module adapter

Follow these steps :

- Remove the 4 screws around the adapter (fig. 2.6).
- Remove the adapter (fig. 2.7).
- Attach the adapter to the Guiding Module, using 4 screws (M4 x 12 mm), making sure the the screws heads are hidden in the adapter (the adapter is not symmetrical). See fig. 2.8.

². Guiding and calibration modules are not part of the UVEX, they must be bought separately

- Make sure that the slit cap is removed!
- Attach back the adapter to the UVEX, and tighten the 4 screws firmly (fig. 2.9). The Guiding module and the UVEX must be strongly attached together, to prevent any movement when the telescope will around the sky.

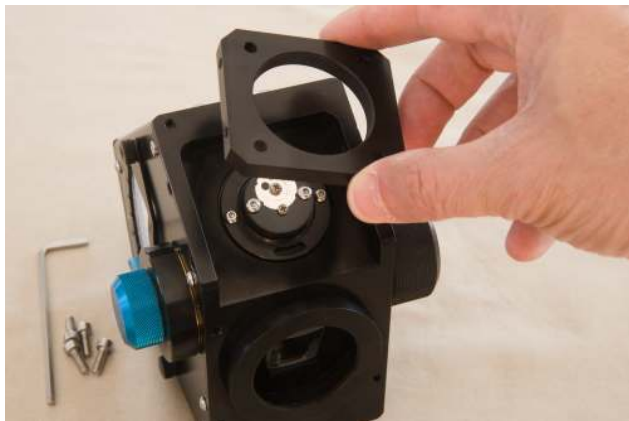

FIGURE 2.7 – Removing the guiding module adapter



FIGURE 2.8 – Install the adapter onto guiding module

2.3 Selecting the Grating Angle

Changing the grating angle changes the part of the spectrum you will observe. In usual conditions, with the low resolution gratings (ie 150 or 300g/mm) you can record almost the whole visible spectrum in one shot³.

The grating angle can be tuned and selected thanks the the vernier, on UVEX main side. The blue button above the index is made to tighten the grating position, once angle is properly selected.



FIGURE 2.9 – Assemble the guiding module and the UVEX

To change the grating angle, first loosen the blue locking button (see fig. 2.10), move slightly the grating angle (see fig. 2.11), and firmly tighten back the locking button (see fig. 2.12). It is key that the grating angle will *never* move during all your observation.



FIGURE 2.10 – Loosen the grating angle locking button

To select the part of the spectrum you will observe, refer to the vernier (note : there is one vernier per grating).

3. This depends on the camera size. The max physical length that the UVEX can cover is 20mm



FIGURE 2.11 – Change the grating angle



FIGURE 2.12 – Lock the grating angle



The grating angle is very sensitive. A small change in the grating angle can make the spectrum move a lot in the image. To get a better precision, take the index by its end.

As soon as you change the grating angle, you must recalibrate your observation, ie make at least new calibration and flat spectra.

2.4 Focusing the Cylindrical Lens

As explained in section 1.3, we've added a cylindrical lens to compensate most part of the natural astigmatism of the Czerny-Turner architecture. Without this lens, the spectrum of a star would be vertically large and fuzzy.

For best results - ie a star spectrum must be a thin line - the cylindrical lens must be focused on your camera. You can clearly see the cylindrical lens before installing the camera. The lens

is mounted on a holder that can slide over few millimeters. The holder is locked by a side screw, and there is a headless screw inside the chassis to stop the holder (see fig. 2.13).

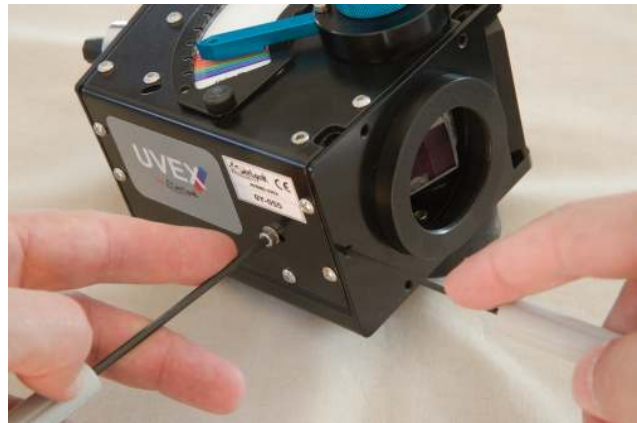

FIGURE 2.13 – Tuning the cylindrical lens

The simplest way to evaluate the cylindric lens focusing is to take continuous spectra of the sky, during daylight (preferably with an optics in front of the UVEX - you can do it directly on the telescope), and look at the top & bottom borders of the spectrum ; they must be as sharp as possible.

During a star observation, a proper focusing gives a sharp (thin) spectrum.

Thus, proceed this way to focus the cylindrical lens :

- Loosen the locking screw,
- move the headless screw until the right position, while taking spectra continuously,
- Tighten the locking screw while pushing toward the headless screw.

2.5 Changing the Grating

The UVEX is shipped with a 600g/mm grating, but there are other grating densities available (150, 300, 1200 and 1800g/mm). Changing the grating will change the dispersion of the instrument, thus its resolution. It will also have a direct effect on the wavelength domain covered by your camera (the lower the resolution, the larger the domain).



The grating surface is very fragile. Make sure that it will never be touched ; a single fingertip can damaged it definitely.

Changing the grating is a simple operation, that can be done even when the UVEX is installed on the telescope. Follow these steps :

→ Loosen, then remove the grating cap (black button on the opposite side of the index). No tool is required, see fig. 2.14) and 2.15



FIGURE 2.14 – Untighten the grating cap



FIGURE 2.15 – Remove the grating cap

→ Remove gently the grating holder, and put it immediately in a protection box. Make sure that no dust can cover the grating surface, and make sure to never put your finger on the optical surface. See fig. 2.16 and 2.17

→ Install the new grating in the UVEX. The grating surface direction is given by the flat surface in the grating holder. This helps you to give the right direction : rotate the grating holder to make the flats surface roughly towards the counter-button (focus). See fig. 2.18 and 2.19

→ The grating module orientation is keyed : rotate the holder until its position is locked.

→ Each grating come with its own vernier, to adapt the spectrum scale to the actual grating.



FIGURE 2.16 – Remove the grating



FIGURE 2.17 – Put the grating in its box

Then, after changing the grating, you must also change the vernier. To do so, loosen the 2 screws around the vernier (no tool required), and slide the vernier out of the UVEX. Do the reverse for the new vernier (see fig. 2.19 and 2.21). Make sure that the vernier position matches exactly the frame, to give a good angle reference.

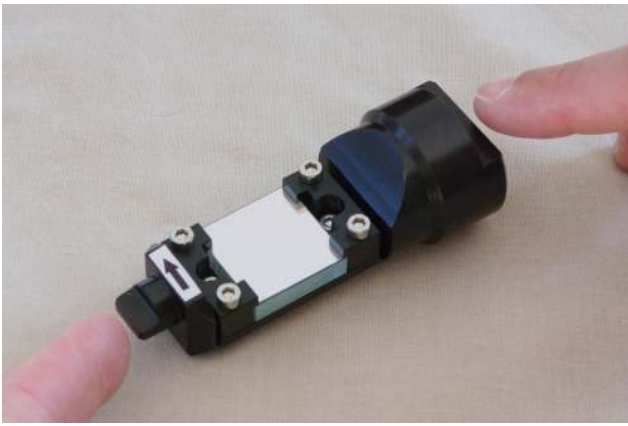

FIGURE 2.18 – Check the grating direction



FIGURE 2.20 – Loosen the vernier screws

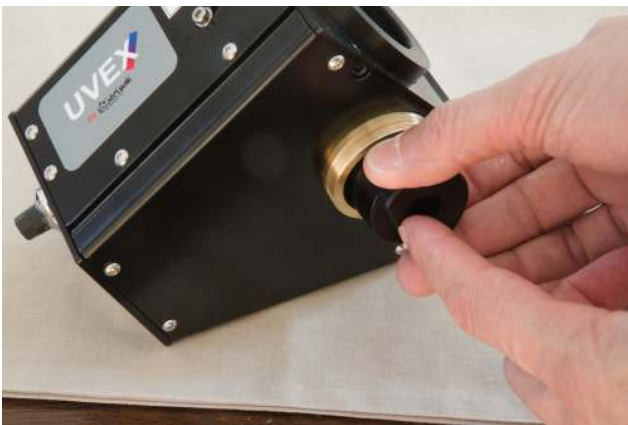

FIGURE 2.19 – Install the new grating



FIGURE 2.21 – Change the vernier

2.6 Installation on the telescope

Once the camera and the guiding module (and probably the calibration module) are attached to the UVEX, all this assembly can be attached to the telescope, using for instance the 2" nose piece adapter (see fig. 2.22 and 2.23).

Make sure that the UVEX is firmly attached to the telescope, to prevent the UVEX to drop down to the ground when the telescope will point toward the zenith. It is highly recommended to wire the UVEX to the telescope for better security.

When all the elements are in place, carefully balance the mount in the two axis. When the breaks of your mount are loosen, the telescope must stay in place, in any position.



The balancing of the mount must be preferably made after all the cables are in place.



FIGURE 2.22 – The UVEX on the telescope



FIGURE 2.23 – The UVEX on the telescope

3

Using the UVEX

Once the instrument is properly installed, it is time to start with stars observations. Understanding the detailed process for making high quality spectroscopic observations is out of the scope of this document, but we'll cover here all practical points you need to know for the UVEX.

We recommend the usage of the Demetra software for acquisition and data reduction. It gives all the features to help you during your observing session.

Important note : Demetra does not handle the telescope control (pointing, and autoguiding). You'll have to use your preferred tool for this function. A good solution that we often use at Shelyak is PHD2¹.

3.1 Focusing the Spectrum

The first point to tune when you observe is the focus of the spectrum. The focus is tuned by the counter-button, at the opposite of the telescope input. The best way to measure the focus point is to take calibration light spectra (Ar-Ne lamp in the Alpy calibration module), and measure the FWHM. There is no internal focal reducer in the UVEX, then the slit images size (ie the calibration lines width, measured with the FWHM) are of same width than the slit itself. For instance, in basic conditions, with a 23 μm slit and an ASI183 camera (pixels of 2.4 μm in bin 1x1), you should get lines FWHM close to 10 μm ($23 / 2.4 = 9.58$).

Once the focus point is found, you can record the numerical value on the counter-button for later use.

Note : Because of the fast beam coming from the calibration module, the optical quality of the calibration lines is better on the left end (blue side) than of the right end (red) of the spectrum².

Then, when you select a calibration line to measure its FWHM, you should prefer a line in the middle of the image, or in the left half of the image.

3.2 Selection of the Central Wavelength

The UVEX has the capability to rotate the grating, to cover a large wavelength range. Selecting the central wavelength is done by turning the blue index on the UVEX side.

The Vernier helps you to select the right angle. However its precision is relative, and you must check the actual wavelength coverage with a spectrum image. Demetra can help you doing so : you'll find in the calibration step a reference calibration spectrum that shows the calibration lines pattern for all wavelengths.



Make sure that the index is somewhere in the visible range, given by the vernier. If the index is out of the colored area of the vernier, you'll get a dark image instead of a spectrum.

Important note : if you're selecting a 'red' region of the spectrum (say above 750nm), there may be some order overlapping. For instance, the second order of a 400 nm wavelength is mixed with the first order at 800 nm. Depending on your target (and your science goal) this may have a large effect on your observation. To avoid this

1. PHD2 is free and Open Source, available for Windows, Linux and Mac. See <https://openphdguiding.org/>
2. This image quality level only affects the calibration lines, and has no effect on the wavelength calibration precision

problem, you may have to install an order filter behind the UVEX slit (refer to Appendix D).

3.3 Tuning the Exposure Time

This is not specific to the UVEX, but when starting the observation of a new target (star), you must select carefully your exposure time. The highest image the better – at the absolute condition to not saturate the image.

When you'll observe faint targets, you'll never face this issue, but for starting with your instrument, we recommend to observe bright stars; in this case you may quickly saturate your camera.

Demetra includes several tools to check that there is no saturation and to help you choosing the best exposure time.

Appendix A : technical specifications

Dimensions

The dimensions of the UVEX are given in fig. 3.1 and 3.2. These dimensions are not including the acquisition camera nor the Guiding and calibration modules.

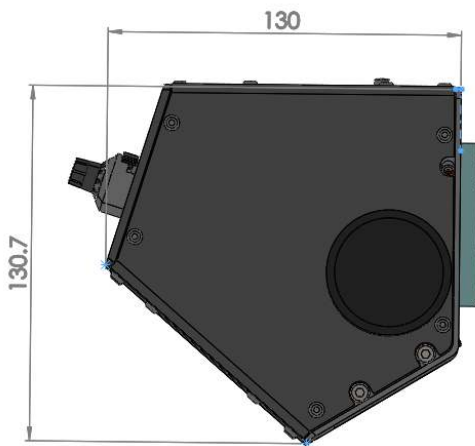

FIGURE 3.1 – Dimensions of the UVEX

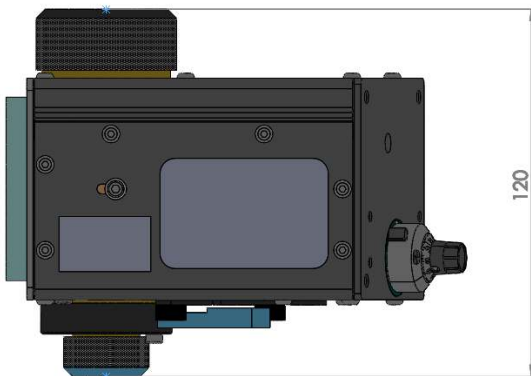

FIGURE 3.2 – Dimensions of the UVEX

Weight

The weight of the UVEX is 1.2 kg.

Gratings

The UVEX is shipped with a 600 l/mm grating, but you can change it to get other resolutions. You can use optional gratings of 150, 300, 1200 and 1800 l/mm gratings. The following table gives you the Resolution Power R^3 for the different gratings.

Note : these are theoretical resolutions (calculated at F/6.5), with the standard slit (width 23 μ m). A wider slit reduces the resolution.

	Grating (l/mm)				
lambda (nm)	150	300	600	1200	1800
350	210	399	824	1748	2863
450	273	530	1100	2364	3947
550	338	671	1397	3044	5217
650	404	821	1715	3798	6738
750	467	944	1973	4501	N/A
850	548	1067	2230	N/A	N/A
950	596	1189	2488	N/A	N/A

FIGURE 3.3 – Theoretical resolutions

Spectrum length

The spectrum physical lens on the sensor is \approx 20mm.

Slit

The UVEX is shipped with a multiple position slit : 25 μ m, 50 μ m, 100 μ m and 300 μ m. There are also a 25 μ m hole position (mainly for test purposes) and a 'slitless' position (3 mm hole).

When used with the guiding module, the slit must be replaced by the one coming with the guiding module. This is a mirror slit. Different slits width can be bought at Shelyak.

3. The resolution power R is given by $R = \lambda/\Delta\lambda$, where λ is the wavelength.

Main camera attachment & back-focus

The main camera (by opposition to the guiding camera) is attached to the UVEX thanks to a special adapter. The standard UVEX includes an adapter for ZWO cameras (such as ASI183 or ASI294). Other adapters are available at Shelyak Instruments for QHY and Atik cameras.

Because of the compact optical layout, there is a strong constraint on the camera backfocus : it must be of 13mm maximum.

Telescope attachment

The UVEX is attached to the telescope through the guiding module. But in addition, the guiding module adapter (shipped with the UVEX) includes a female T-mount thread (M42 x 0.75 mm), that can be used to attach any optics or device (see fig. 3.4).

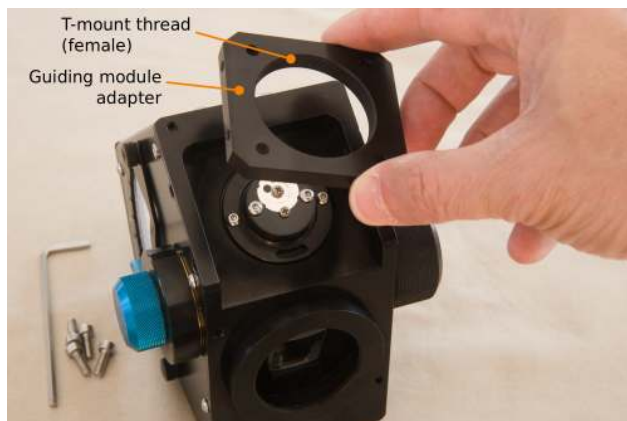

FIGURE 3.4 – Telescope adapter

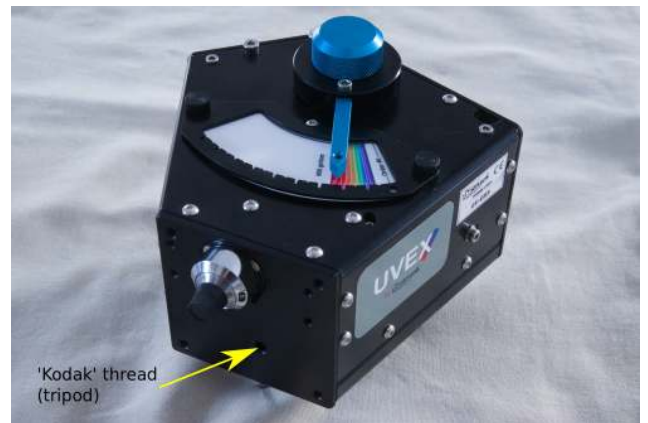

FIGURE 3.5 – Tripod thread

Tripod thread

Close to the counter-button, you have a 'Kodak thread' to attach a tripod, to use the UVEX in a laboratory (see fig. 3.5).

Appendix B : changing the slit

You can easily access and change the slit of the UVEX.

First, you can loosen the 2 small screws attaching the slit itself, and rotate it to the position you choosed. After the slit selection, we recommend to take images to control that the emission or absorption lines are vertical.

 In normal conditions, the spectrum (direction of the dispersion) must be perfectly horizontal in your image and the lines – if you've an extended light source – must be perfectly vertical. The perpendicularity between the spectrum dispersion and the lines is achieved if the slit is exactly parallel to the grating lines (grooves). If you rotate a little bit the slit, then the lines will be slanted in your spectrum. Reversly, if you want to make the lines perfectly perpendicular to the dispersion direction, adjust precisely the slit orientation.

Second, you can change the whole slit, and replace it, for instance, by a mirror-slit (this is the case for use with the guiding module). See fig. 3.6, 3.7 and 3.8.

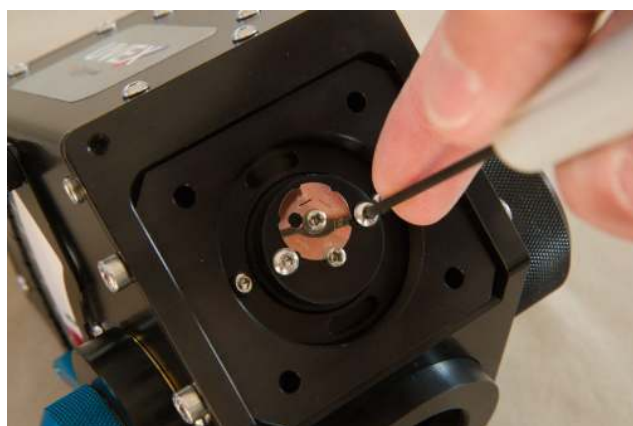

FIGURE 3.6 – Remove the slit holder screws

Third, you can return the external slit holder (after removing the slit holder) to install a fiber optic connector (available in option at Shelyak). See 3.9 and 3.10.



FIGURE 3.7 – Remove the slit holder



FIGURE 3.8 – Tighten the screw for the new slit

In any case, after changing the slit, you must refocus the spectrum – or at least check it is OK.



FIGURE 3.9 – Remove the external slit holder



FIGURE 3.10 – Return the external slit holder to install a fiber connector

Appendix C : installing the order filter

If you observe in far red or even in IR with the UVEX, there is a risk that the blue light at second order overlaps your spectrum. This is a very common issue, for any grating spectroscopes. The solution to avoid this is to use a filter that will cut all light below 500nm. Such filter is available at Shelyak Instruments.

The UVEX can hold such an order filter, right after the slit. To install it, proceed as follows :

→ Remove the external slit holder (see fig. 3.11



FIGURE 3.11 – Remove the external slit holder

→ Install the filter (this is a 1/2" diameter - see fig. 3.12 and 3.13)



FIGURE 3.12 – Install the filter

→ Put and tighten (gently!) the locking ring (see fig. 3.14 and 3.15)



FIGURE 3.13 – Install the filter



FIGURE 3.14 – Install the locking ring



FIGURE 3.15 – Tighten the locking ring

Appendix D : screws functions

The UVEX contains a lot of screws ; of course each of them has a precise function. Some screws can be manipulate for tuning, but the other must not be loosen or removed – they are part of the structure of the instrument.

In the below pictures, we've shown all screw that could be manipulated with no (major) risk. All the other screws must not be removed.

We've indicated with colors the different functions :

- Telescope attachment (blue)
- Cylindrical lens focus (violet)
- Vernier (green)
- Cover opening (red)
- M1 tilt tuning (yellow)

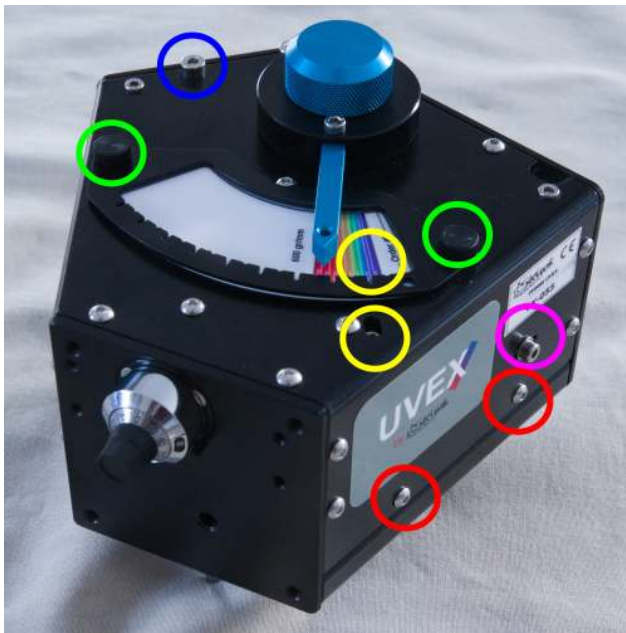

FIGURE 3.16 – UVEX screws

Important Note : You never need to 'open the box' of the UVEX. But if you cannot resist (or if you really need to), first remove the grating cap, then the grating itself. After that, you can simply remove 9 screws (in red in these pictures) and slide it gently.



FIGURE 3.17 – UVEX screws

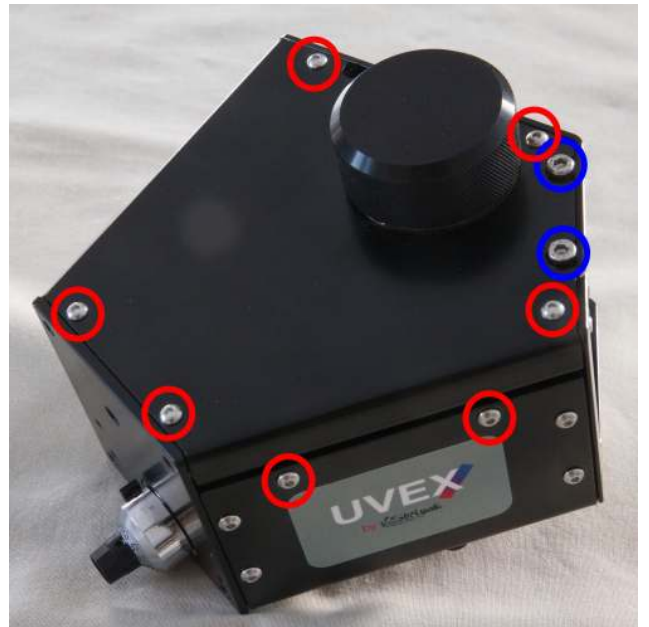

FIGURE 3.18 – UVEX screws

Appendix E : tuning M1 mirror tilt

In normal conditions, you should never have to tune the M1 mirror tilt, because the instrument is tuned in our factory. But we never and we prefer to give you all the details to do it if needed.

All the UVEX optics is contained in a plane, and then the spectrum is 'absolutely' symmetric vertically (across the dispersion direction). Of course, nothing is really perfect, and the even if all optical and mechanical parts are of high quality, we cannot ensure only by construction that the whole optics is perfectly planar. Then, we've given some tuning room to the M1 mirror (see the optical layout in section 1.3) to make all the elements exactly in a plane.

The symptom, if the M1 tuning is not perfect is that the spectrum of an extended source will not be exactly symmetrical. For instance, if you take a spectrum of the Sky (with a telescope or any optics in front of the slit), the spectrum is sharp in the central part, but less sharp on top and bottom edges. The M1 tuning will affect this symmetry. Then if you can see that the sharpest part of the spectrum is not exactly at the center of the spectral band, you can improve this with M1 tilt.

The M1 mirror is mounted on a holder that allows a rotation around its center (see CAD views inside the UVEX fig. 3.19 and 3.20).

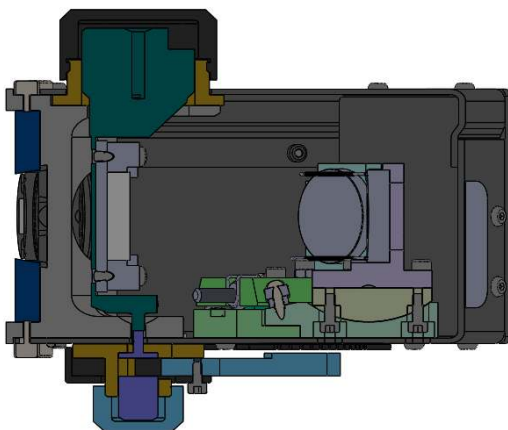

FIGURE 3.19 – Inside the UVEX

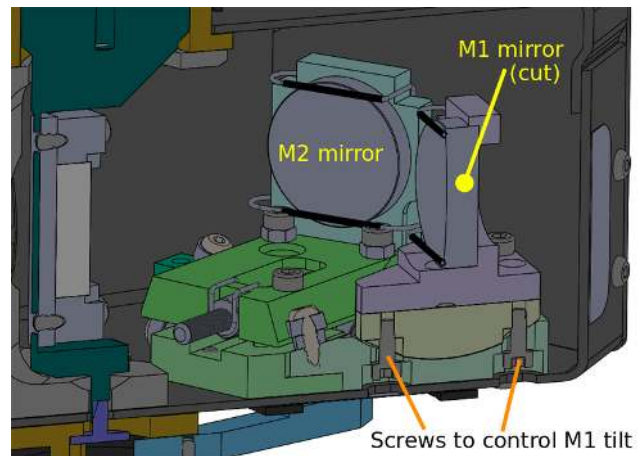

FIGURE 3.20 – Inside the UVEX

You can control the rotation of the M1 mirror by the two external screws showed on fig. 3.21.

Important note : one of the two screws is under the vernier. Then you must remove the vernier prior to this tuning.



FIGURE 3.21 – Screws to control M1 tilt angle

Be very careful when doing this tuning. The mirror angle is very sensitive.